

MAILBOX APPROACHES

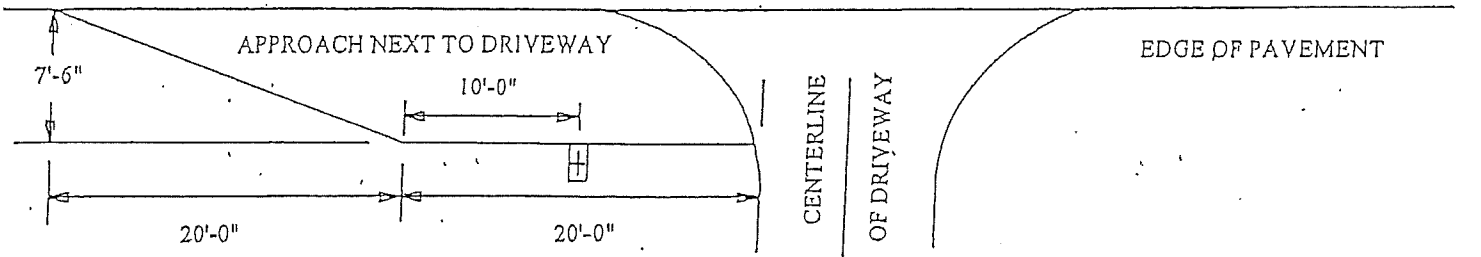

ACCEPTABLE POST MATERIALS

1. 4"x 4" SQUARE OR 4 1/2" ROUND WOOD
2. MAX. 2" DIA. STEEL PIPE, 23/8" O.D.
3. ANY MATERIAL WITH SAME BREAKAWAY CHARACTERISTICS AS 1. & 2.
4. MULTIPLE BOXES ARE TO BE ON 3' CENTERS WITH 3' ADDED TO APPROACH CENTER SECTION
5. *12"- 304 GRAVEL TO BE USED FOR BASE MATERIAL WITH SURFACE SAME AS PAVEMENT

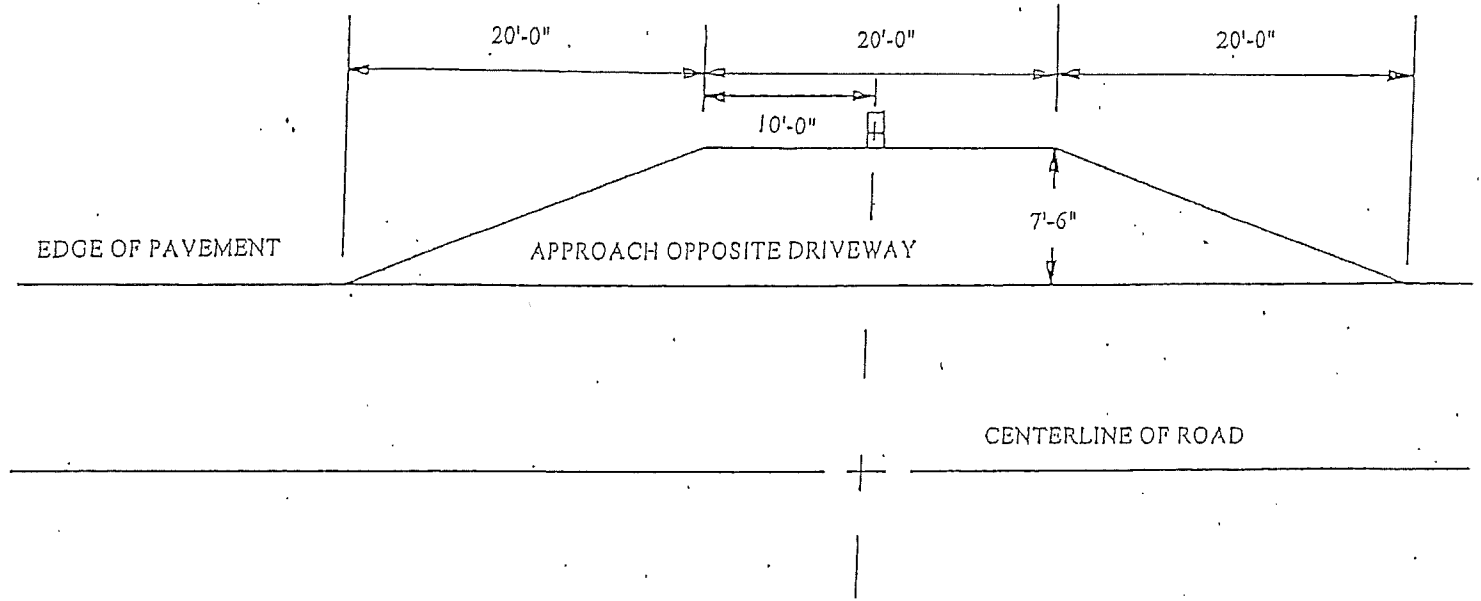
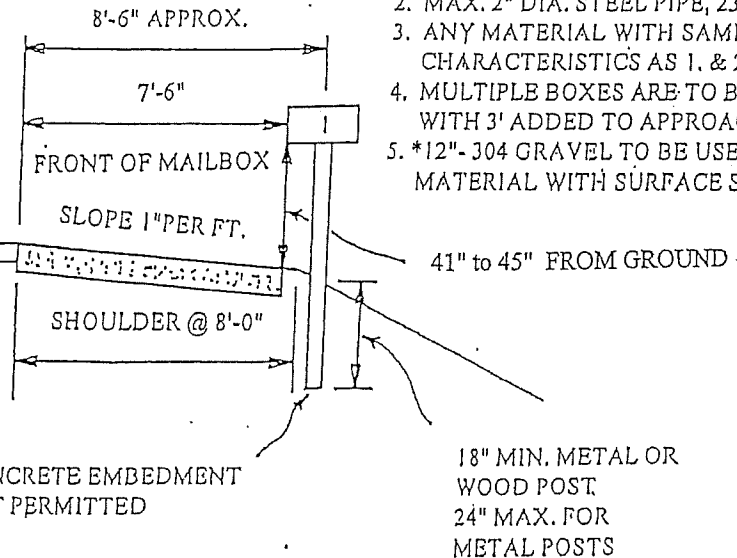

Ohio Utilities Protection Service

Call 811
before you dig